

## SINGLE OUTLET TWO HANDLE THERMOSTATIC CONCEALED VALVE

Category: showers

Volume: 0.02

Weight: 4.00

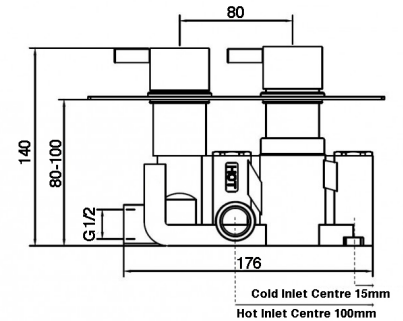
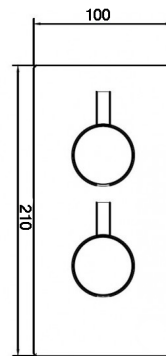

Dimensions are in millimetres except thread sizes which are BSP imperial.

### Flow Rates

Pressure (bar)	0.2	0.5	1.0	1.5	2.0	2.5	3.0	4.0	5.0	6.0
Rates	7	10.1	12.8	14.6	16.5	18.2	19.5			

Flow rates are in litres per minute under factory conditions; actual rates will depend on the local installation.

### Features

### Notes

Our guarantee is subject to the product having been installed, used and maintained in accordance with our instructions. All working parts (such as hinges, ceramic disks, cartridges, seals and cistern fittings), which are subject to normal wear and tear, are covered for 36 months from proof of purchase date. This excludes seats, which are covered for 12 months. Our guarantee applies to the original purchaser and is nontransferable. Our guarantee is only applicable in the UK and ROI. This does not affect your statutory rights.

We recommend that a pressure reducing valve is fitted in installations where the water supply pressure exceeds 3 bar. Pressure in excess of 3 bar could reduce the working life of this product and invalidate the guarantee.

Information is provided for guidance only and is non-binding. All measurements are approximate and subject to standard tolerances. We reserve the right to change product specifications without prior notification.

## TWIN OUTLET TWO HANDLE THERMOSTATIC CONCEALED VALVE

Category: showers

Volume: 0.02

Weight: 4.00

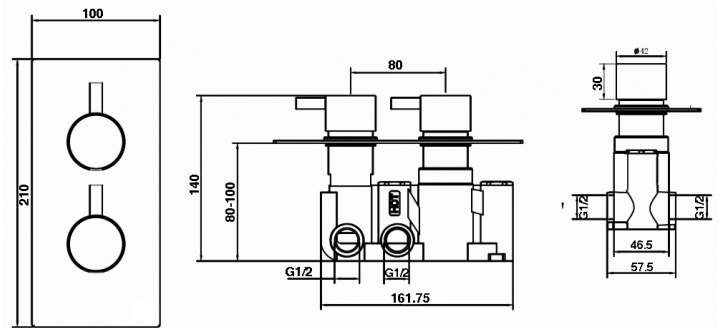

Dimensions are in millimetres except thread sizes which are BSP imperial.

### Flow Rates

Pressure (bar)	0.2	0.5	1.0	1.5	2.0	2.5	3.0	4.0	5.0	6.0
Rates		9	11.1	12.8	14.2	15.4	16.5			

Flow rates are in litres per minute under factory conditions; actual rates will depend on the local installation.

### Features

### Notes

Our guarantee is subject to the product having been installed, used and maintained in accordance with our instructions. All working parts (such as hinges, ceramic disks, cartridges, seals and cistern fittings), which are subject to normal wear and tear, are covered for 36 months from proof of purchase date. This excludes seats, which are covered for 12 months. Our guarantee applies to the original purchaser and is nontransferable. Our guarantee is only applicable in the UK and ROI. This does not affect your statutory rights.

We recommend that a pressure reducing valve is fitted in installations where the water supply pressure exceeds 3 bar. Pressure in excess of 3 bar could reduce the working life of this product and invalidate the guarantee.

Information is provided for guidance only and is non-binding. All measurements are approximate and subject to standard tolerances. We reserve the right to change product specifications without prior notification.

## TWIN OUTLET TRIPLE CONTROL CONCEALED THERMOSTATIC VALVE WITH ABS COVERPLATE

Category:	showers		
Guarantee:	10 year		
Type:	thermostatic concealed shower valves	Volume:	0.01
Weight:	3.10		

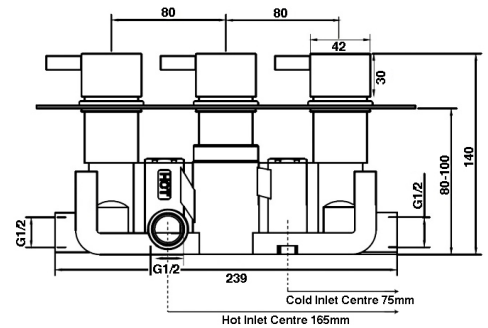
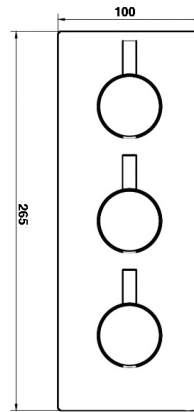

Dimensions are in millimetres except thread sizes which are BSP imperial.

### Flow Rates

Pressure (bar)	0.2	0.5	1.0	1.5	2.0	2.5	3.0	4.0	5.0	6.0
Rates	14	16	20.5	25	27.5	29	32			

Flow rates are in litres per minute under factory conditions; actual rates will depend on the local installation.

### Features

- Advanced anti-scald technology

### Notes

Our guarantee is subject to the product having been installed, used and maintained in accordance with our instructions. All working parts (such as hinges, ceramic disks, cartridges, seals and cistern fittings), which are subject to normal wear and tear, are covered for 36 months from proof of purchase date. This excludes seats, which are covered for 12 months. Our guarantee applies to the original purchaser and is nontransferable. Our guarantee is only applicable in the UK and ROI. This does not affect your statutory rights.

We recommend that a pressure reducing valve is fitted in installations where the water supply pressure exceeds 3 bar. Pressure in excess of 3 bar could reduce the working life of this product and invalidate the guarantee.

Information is provided for guidance only and is non-binding. All measurements are approximate and subject to standard tolerances. We reserve the right to change product specifications without prior notification.

## WALL-MOUNTED SHOWER ARM 360MM

Category:	showers		
Guarantee:	10 year		
Type:	shower heads, arms and wall outlet elbows	Volume:	0.01
Weight:	0.51		



Dimensions are in millimetres except thread sizes which are BSP imperial.

### Features

### Notes

Our guarantee is subject to the product having been installed, used and maintained in accordance with our instructions. All working parts (such as hinges, ceramic disks, cartridges, seals and cistern fittings), which are subject to normal wear and tear, are covered for 36 months from proof of purchase date. This excludes seats, which are covered for 12 months. Our guarantee applies to the original purchaser and is nontransferable. Our guarantee is only applicable in the UK and ROI. This does not affect your statutory rights.

We recommend that a pressure reducing valve is fitted in installations where the water supply pressure exceeds 3 bar. Pressure in excess of 3 bar could reduce the working life of this product and invalidate the guarantee.

Information is provided for guidance only and is non-binding. All measurements are approximate and subject to standard tolerances. We reserve the right to change product specifications without prior notification.

## SINGLE FUNCTION HANDSET WITH AIR MIX

Category: showers

Volume: 0.00

Weight: 0.50

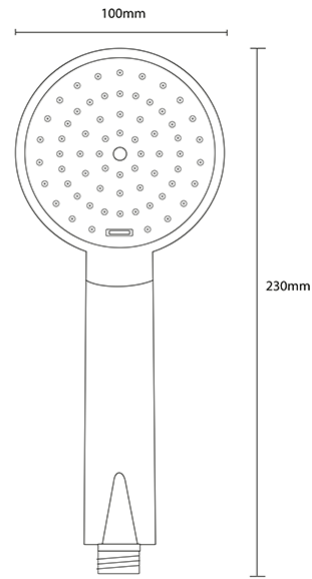

Dimensions are in millimetres except thread sizes which are BSP imperial.

### Features

### Notes

Our guarantee is subject to the product having been installed, used and maintained in accordance with our instructions. All working parts (such as hinges, ceramic disks, cartridges, seals and cistern fittings), which are subject to normal wear and tear, are covered for 36 months from proof of purchase date. This excludes seats, which are covered for 12 months. Our guarantee applies to the original purchaser and is nontransferable. Our guarantee is only applicable in the UK and ROI. This does not affect your statutory rights.

We recommend that a pressure reducing valve is fitted in installations where the water supply pressure exceeds 3 bar. Pressure in excess of 3 bar could reduce the working life of this product and invalidate the guarantee.

Information is provided for guidance only and is non-binding. All measurements are approximate and subject to standard tolerances. We reserve the right to change product specifications without prior notification.