

ARCO SHOWER BATH 1700MM RIGHT HAND (INC LEG PACK 3)

Category:	baths	Code:	PBSBRH17
Guarantee:	25 year	Range:	Arco
Type:	showerbaths	Volume:	0.19
Weight:	36.00		

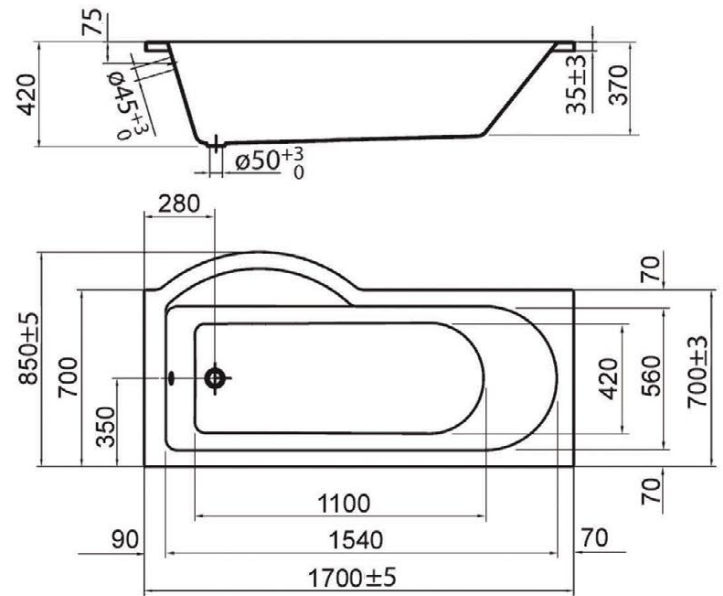

Dimensions are in millimetres except thread sizes which are BSP imperial.

Features

- Excludes wastes, taps
- Includes leg pack
- 170 litre capacity

Notes

Our guarantee is subject to the product having been installed, used and maintained in accordance with our instructions. All working parts (such as hinges, ceramic disks, cartridges, seals and cistern fittings), which are subject to normal wear and tear, are covered for 36 months from proof of purchase date. This excludes seats, which are covered for 12 months. Our guarantee applies to the original purchaser and is nontransferable. Our guarantee is only applicable in the UK and ROI. This does not affect your statutory rights.

We recommend that a pressure reducing valve is fitted in installations where the water supply pressure exceeds 3 bar. Pressure in excess of 3 bar could reduce the working life of this product and invalidate the guarantee.

Information is provided for guidance only and is non-binding. All measurements are approximate and subject to standard tolerances. We reserve the right to change product specifications without prior notification.

ARCO SHOWER BATH 1500MM RIGHT HAND (INC LEG PACK 3)

Category:	baths	Code:	PBSBRH15
Guarantee:	25 year	Range:	ARCO
Type:	showerbaths	Volume:	0.16
Weight:	34.00		

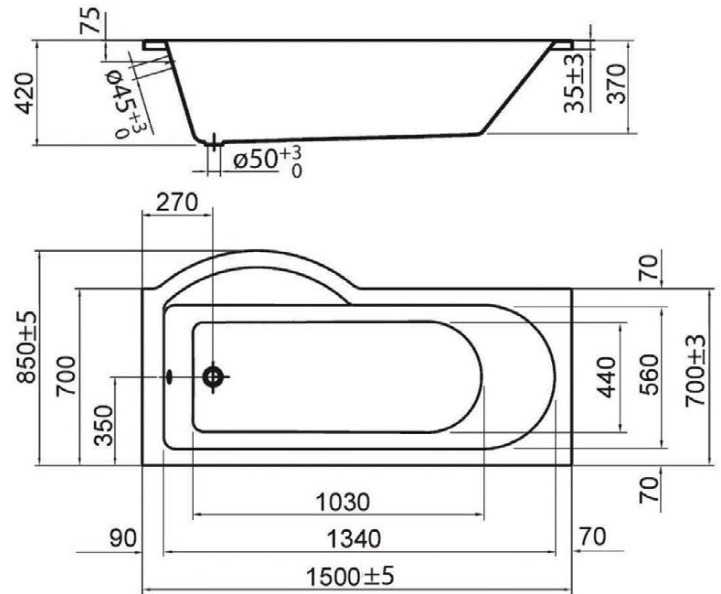

Dimensions are in millimetres except thread sizes which are BSP imperial.

Features

- Excludes wastes, taps
- Includes leg pack
- 157 litre capacity

Notes

Our guarantee is subject to the product having been installed, used and maintained in accordance with our instructions. All working parts (such as hinges, ceramic disks, cartridges, seals and cistern fittings), which are subject to normal wear and tear, are covered for 36 months from proof of purchase date. This excludes seats, which are covered for 12 months. Our guarantee applies to the original purchaser and is nontransferable. Our guarantee is only applicable in the UK and ROI. This does not affect your statutory rights.

We recommend that a pressure reducing valve is fitted in installations where the water supply pressure exceeds 3 bar. Pressure in excess of 3 bar could reduce the working life of this product and invalidate the guarantee.

Information is provided for guidance only and is non-binding. All measurements are approximate and subject to standard tolerances. We reserve the right to change product specifications without prior notification.