

TECHNICAL DATA SHEET
SHOWER BATH 1500 LEFT HAND

Category:	baths	Volume:	0.16
Guarantee:	25 year		
Type:	showerbaths		
Weight:	24.00		

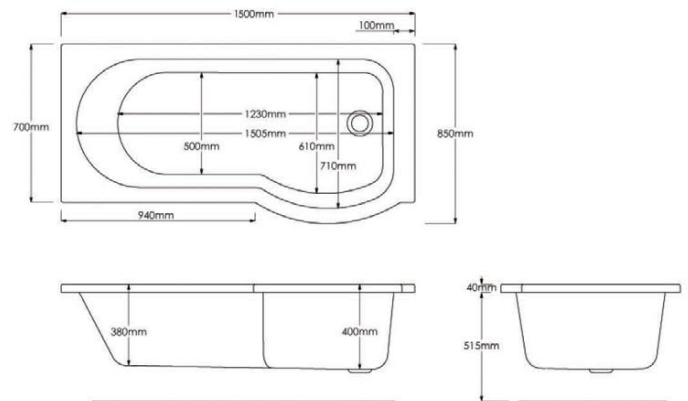

Dimensions are in millimetres except thread sizes which are BSP imperial.

Features

- Excludes wastes, taps
- Includes leg pack
- 220 litre capacity

Notes

Our guarantee is subject to the product having been installed, used and maintained in accordance with our instructions. All working parts (such as hinges, ceramic disks, cartridges, seals and cistern fittings), which are subject to normal wear and tear, are covered for 36 months from proof of purchase date. This excludes seats, which are covered for 12 months. Our guarantee applies to the original purchaser and is nontransferable. Our guarantee is only applicable in the UK and ROI. This does not affect your statutory rights.

We recommend that a pressure reducing valve is fitted in installations where the water supply pressure exceeds 3 bar. Pressure in excess of 3 bar could reduce the working life of this product and invalidate the guarantee.

TECHNICAL DATA SHEET SHOWER BATH 1500 RIGHT HAND

Category:	baths	Volume:	0.16
Guarantee:	25 year		
Type:	showerbaths		
Weight:	24.00		

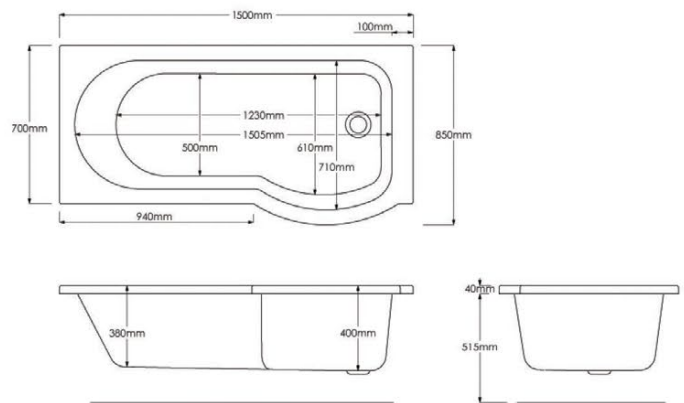

Dimensions are in millimetres except thread sizes which are BSP imperial.

Features

- Excludes wastes, taps
- Includes leg pack
- 220 litre capacity

Notes

Our guarantee is subject to the product having been installed, used and maintained in accordance with our instructions. All working parts (such as hinges, ceramic disks, cartridges, seals and cistern fittings), which are subject to normal wear and tear, are covered for 36 months from proof of purchase date. This excludes seats, which are covered for 12 months. Our guarantee applies to the original purchaser and is nontransferable. Our guarantee is only applicable in the UK and ROI. This does not affect your statutory rights.

We recommend that a pressure reducing valve is fitted in installations where the water supply pressure exceeds 3 bar. Pressure in excess of 3 bar could reduce the working life of this product and invalidate the guarantee.

TECHNICAL DATA SHEET SHOWER BATH 1675 LEFT HAND

Category:	baths	Volume:	0.16
Guarantee:	25 year		
Type:	showerbaths		
Weight:	26.00		

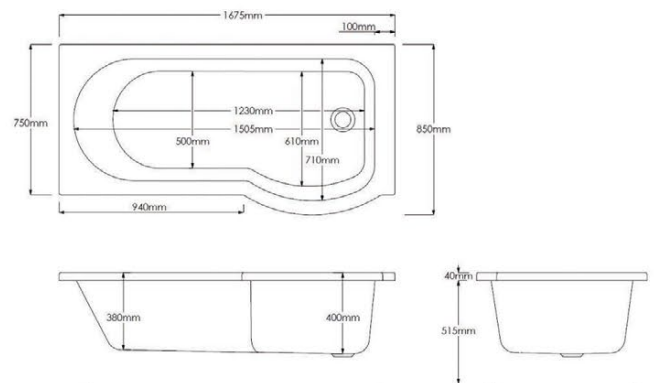

Dimensions are in millimetres except thread sizes which are BSP imperial.

Features

- Excludes wastes, taps
- Includes leg pack
- 240 litre capacity

Notes

Our guarantee is subject to the product having been installed, used and maintained in accordance with our instructions. All working parts (such as hinges, ceramic disks, cartridges, seals and cistern fittings), which are subject to normal wear and tear, are covered for 36 months from proof of purchase date. This excludes seats, which are covered for 12 months. Our guarantee applies to the original purchaser and is nontransferable. Our guarantee is only applicable in the UK and ROI. This does not affect your statutory rights.

We recommend that a pressure reducing valve is fitted in installations where the water supply pressure exceeds 3 bar. Pressure in excess of 3 bar could reduce the working life of this product and invalidate the guarantee.

TECHNICAL DATA SHEET SHOWER BATH 1675 RIGHT HAND

Category:	baths	Volume:	0.16
Guarantee:	25 year		
Type:	showerbaths		
Weight:	26.00		

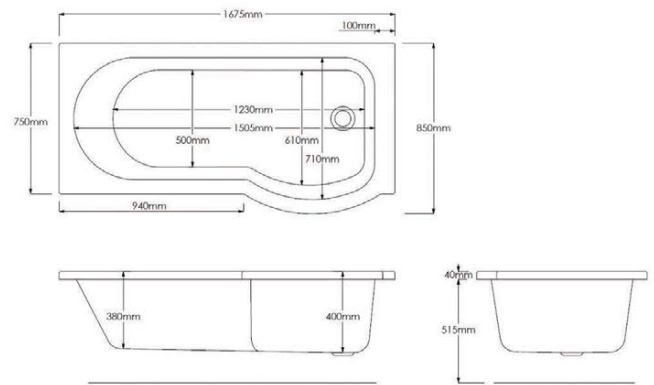

Dimensions are in millimetres except thread sizes which are BSP imperial.

Features

- Excludes wastes, taps
- Includes leg pack
- 240 litre capacity

Notes

Our guarantee is subject to the product having been installed, used and maintained in accordance with our instructions. All working parts (such as hinges, ceramic disks, cartridges, seals and cistern fittings), which are subject to normal wear and tear, are covered for 36 months from proof of purchase date. This excludes seats, which are covered for 12 months. Our guarantee applies to the original purchaser and is nontransferable. Our guarantee is only applicable in the UK and ROI. This does not affect your statutory rights.

We recommend that a pressure reducing valve is fitted in installations where the water supply pressure exceeds 3 bar. Pressure in excess of 3 bar could reduce the working life of this product and invalidate the guarantee.